

Weldclass®



OPERATING MANUAL FOR Promax 600 Series ELECTRONIC WELDING HELMETS



WARNING



THIS PRODUCT CONTAINS A BUTTON BATTERY

A lithium button battery can cause severe or fatal injuries in 2 hours or less if it is swallowed or placed inside any part of the body.

Keep batteries out of reach of children.

If you think batteries may have been swallowed or placed inside any part of the body, seek immediate medical attention.

Video/Web Manual



Weldclass.com.au/guide600

CONTENTS

Section	Details
1	BEFORE YOU START... IMPORTANT INFORMATION
2	SPECIFICATIONS
3	AUTO-DARKENING FILTER/LENS (ADF) CONTROLS & FEATURES
4	REPLACING ACCESSORIES & MAKING ADJUSTMENTS
5	SPARE PARTS LIST
6	MAINTENANCE
7	TROUBLESHOOTING
8	WARRANTY

1 / BEFORE YOU START – IMPORTANT INFORMATION

Warning: Incorrect use of this product may cause serious injury.

- a. All users of this helmet should read & understand this manual before using the product
- b. Use this helmet only for the intended application as described in this manual
- c. Each time the helmet is used, it should be checked for correct operation: Use a cigarette lighter or strong light source to check that the lens is activating correctly.
- d. Stop welding immediately if the helmet filter/lens fails to darken when the arc is struck. Do not continue use until the malfunction has been rectified. Read this manual for further information and if in doubt, return the helmet to your Weldclass distributor for further inspection.
- e. This welding helmet does NOT provide unlimited protection. All appropriate PPE and safety-wear must be worn, and safe work practices must be followed at all times, in accordance with applicable industry OH&S regulations. Arc rays can burn eyes and skin. Fumes and Gases can be hazardous. Noise can damage hearing. Flying particles can cause impact injury or death.
- f. Never use the helmet without the outer & inner cover lenses correctly installed. Failure to do so will damage the Auto-darkening filter & void warranty.** Always keep clear cover lenses clean and replace them regularly. Dirty or scratched cover lenses may cause the auto-darkening filter to malfunction.

2 / SPECIFICATIONS

	Promax 600	Promax 650	Promax 680
Suitable Applications	MIG, MMA (stick), TIG, Plasma Cutting, Oxy Cutting (Brazing, Arc Gouging)		
TIG Suitability	5 amps or more		
Optical Class	V2 (1/1/1/2)	V1 (1/1/1/1)	
Switching Speed	Conforms to & exceeds the requirements of AS/NZS1338.1 & ISO16321-2		
Sensors	4		4 + 1 Intensity
Power Supply	2 x CR2450 replaceable battery (assisted by Solar panels)		
On / Off	Ready to weld at any time – no switching required		
Low Battery Indicator	Battery level indicator on Digital Screen		
Inactive Shade Level (Grind/Off)	3		
Active Shade Level (Weld)	4-8 / 9-13		4-8 / 9-14
Sensitivity Adjustment	Low - High (9 levels)		
Delay Adjustment	Min 0.04 sec – Max 2.0 sec with Gradient function		
Grinding Mode	Yes, internal	Yes, internal and external push button	
Operating Temperature	-10°C to +60°C		
Storage Temperature	-25°C to +65°C		
Weight	562 g	568 g	620 g
Viewing Area	108x74 mm	108x82 mm	116x82 mm
Outer Cover Lens Dimensions	178x130mm		
Inner Cover Lens Dimensions	114x90 mm		112x86 mm
Magnification Lens Holder	Internal – takes standard 108x51mm magnifications lenses		
Standards Compliance - Shell	AS/NZS1337.1 High Impact		
Standards Compliance – Auto Darkening Filter/Lens	AS 1338.1, ISO 16321-2, ANSI Z87.1, CSA Z94.3		

3 / AUTO-DARKENING FILTER/LENS (ADF) CONTROLS & FEATURES

Promax 600 & 650 Controls:

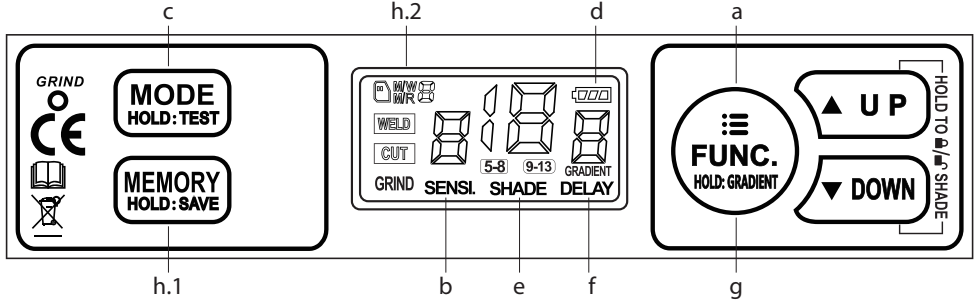

Promax 680 Controls:

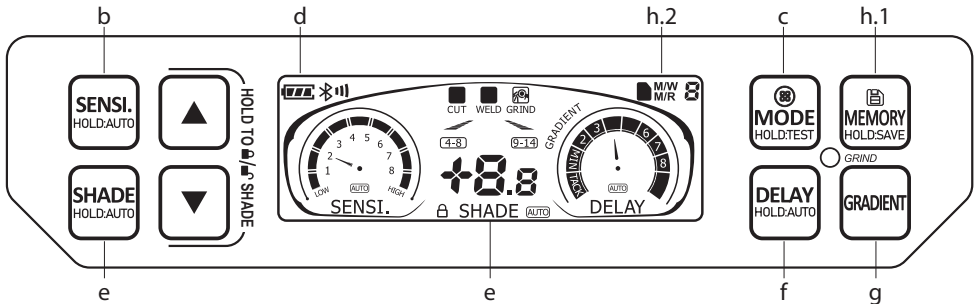

	MODE	Short press	Switch between WELD, CUT, SHADE LOCK
		Long press	Switch between AUTO or MANUAL Shade
	BUTTON	Short press	Current settings will save to memory record 0
		Long press	Grind Mode on/off
	DIAL	Twist to adjust Shade	Manual Shade Mode: Adjust shade by ± 0.5
			Auto Shade Mode: Adjust shade deviation by ± 0.5

For full details/instructions on the use of these controls, see weldclass.com.au/guide600 or scan QR Code on page 2 of this manual.

Note: ADF = Auto-Darkening Filter/Lens Cassette

a. FUNCTION BUTTON (FUNC.) (Promax 600 & Promax 650 only)

This scroll through Sensitivity, Shade & Delay settings. Press the Up and Down buttons to adjust the Function that is flashing. Once adjusted, wait for the setting to stop flashing to store the new value.

b. SENSITIVITY CONTROL (SENSI)

This adjusts the sensitivity of the arc sensors to best suit the welding task & surrounding environment. Low sensitivity helps prevent the ADF from reacting to other nearby light sources. High sensitivity may be required if welding on low current &/or when TIG welding. Low to mid sensitivity is recommended for most welding applications. **Press and Hold for Auto Sensitivity (Promax 680 only).**

3 / AUTO-DARKENING FILTER (ADF) CONTROLS & FEATURES – Cont'd

c. MODE BUTTON

This changes between WELD 9-13, WELD 4-8, CUT, and GRIND modes. Also, press and hold this button to test/check ADF is operating correctly.

d. BATTERY LEVEL INDICATOR

e. SHADE ADJUSTMENT (SHADE)

The following chart shows recommended shade levels for different welding applications. **Press and Hold for Auto Shade (Promax 680 only).**

Welding Application	Arc Current in Amps	Protective Shade No.
Stick Electrode (MMA)	Less than 40	9
	40-80	10
	80-175	11
	175-300	12
	300-500	13
MIG	Less than 100	10
	100-175	11
	175-300	12
	300-500	13
TIG	Less than 50	8-10
	50-100	11
	100-200	12
	200-400	13
Air Carbon Arc Gouging	Less than 500	12
	500-700	13
Plasma Arc Cutting	Less than 80	8-9
	80-150	10-11
	150-350	12-13
Gas Welding & Cutting	-	4-6

f. TIME DELAY ADJUSTMENT (DELAY)

This adjusts the time the ADF switches from dark back to light when welding stops. A short delay time is best for tack welding and short welds. A longer delay may be required if welding heavier materials, where the welding pool emits bright light for a brief period **Press and Hold for Auto Delay (Promax 680 only).**

g. GRADIENT FUNCTION

Activate this by pressing the FUNC. Button for 2 seconds (Promax 600 & 650)

Activate this by pressing the GRADIENT Button (Promax 680 only).

When this is active the shade will 'slope down' from your set welding shade setting to shade 3. This mirrors the cooling of the weld pool, to reduce eye strain.

h. MEMORY SAVE

You can save up to 10 of your favourite settings.

M/R = Memory Recall, this will display when you are trying to Recall a saved Memory

setting. M/W = Memory Write, this will display when you are Saving a Memory

Setting. The Number represents the Memory number slot you are saving to or

recalling. Use the Up and Down buttons to scroll through the memory Slots. Wait for

5 seconds after selecting the desired memory slot to save or recall these settings.

4 / REPLACING ACCESSORIES & MAKING ADJUSTMENTS

REPLACING BATTERIES

When the batteries have become discharged. You can view the battery level status on the Digital Display (h).

Remove the Front cover lens before removing the ADF. For the Promax 650 also remove the Grind Switch by unscrewing the button retainer ring and pushing the button into the inside of the helmet.

Remove the ADF by pressing down on the 2 tabs (i) at the top of the ADF while simultaneously pressing the ADF forwards out of the front of the helmet.

Remove the screws holding the battery holders in place and remove the holders.

Reverse these steps to re-assemble the helmet once new batteries are installed.

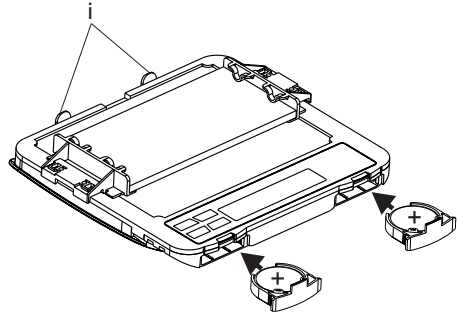

REPLACING COVER LENSES

Replacing Front Cover Lens: Firmly pull 1 side of the Cover lens forwards. Once 1 side is released the other side will come free.

Replacing Inner Cover Lens: Using the access point at the top of the ADF, pull the lens backwards so the lens bends and the corners release from their holders.

NOTE: If you have the mag lens holders installed, you may need to remove the whole cassette first. (see above instructions for Replacing Batteries)

IMPORTANT: Use only original Weldclass cover lenses to ensure correct fit and conformance to safety standards.

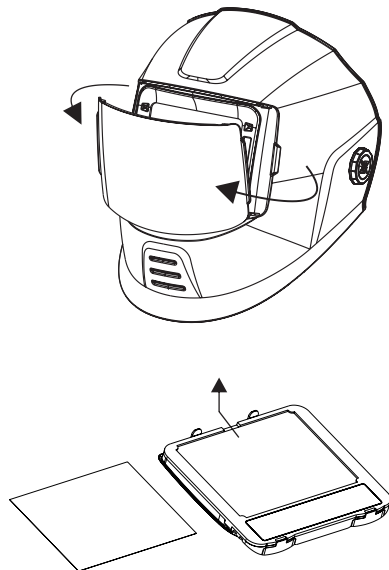

4 / REPLACING ACCESSORIES & MAKING ADJUSTMENTS – Cont'd

INSTALLING A MAGNIFICATION LENS

Install the 2 Magnification Lens holder clips (i) (supplied as separate parts with helmet) to the mounting positions on either side of the viewing window. These will click firmly into place.

Any standard 108x51mm magnification lens can be fitted to these clips.

Note: To prevent fogging, place the flat side of the magnification lens towards the ADF (auto-darkening filter/lens).

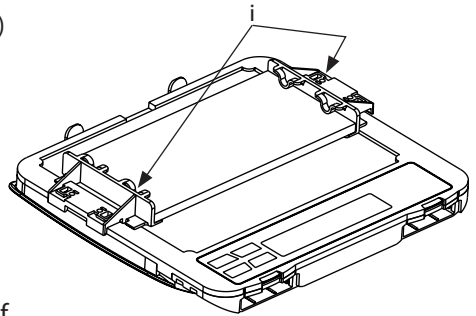

HEADGEAR ADJUSTMENT

For full details on headgear adjustments, see web manual at weldclass.com.au/guide600 or scan the QR code on page 2 of this manual.

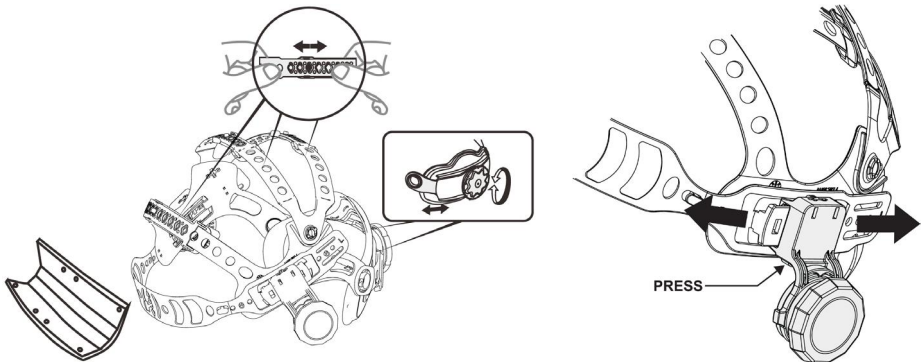

5 / SPARE PARTS

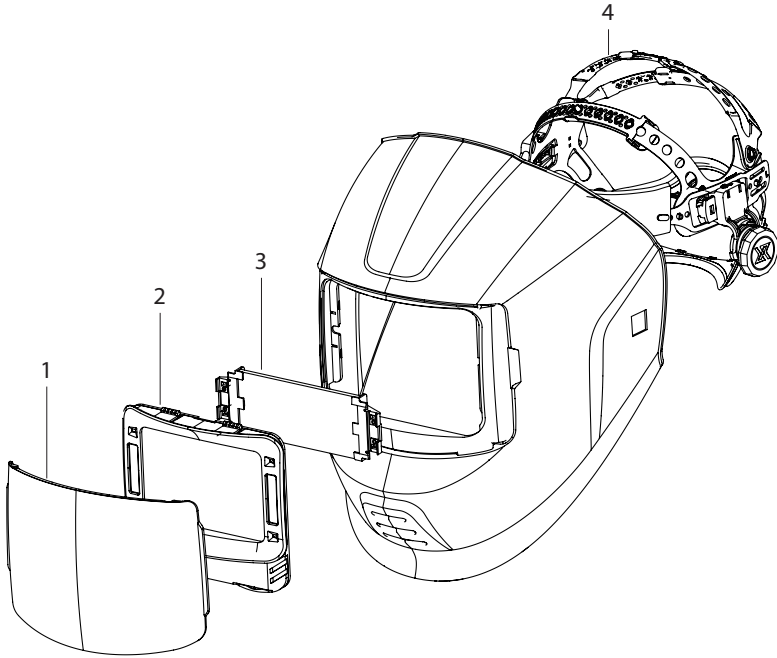

REF	DESCRIPTION	PART NO
1	Outer Clear Cover Lens (each)	WC-05352
-	Cover Lens Kit 2 Outer + 1 Inner	WC-05351
2	Auto-Darkening Filter Cassette (ADF) Promax 600	WC-05346
	Auto-Darkening Filter Cassette (ADF) Promax 650	WC-05349
	Auto-Darkening Filter Cassette (ADF) Promax 680	WC-05354
-	Inner Clear Cover Lens 114 x 90mm Pk5 Promax 600/650	WC-05350
-	Inner Cover Lens 121 x 86mm Pk5 Promax 680	WC-05357
-	Sweat Band Pkt 5	WC-01630
4	Headgear Assembly	WC-05353
-	Battery (CR2450) (Not pictured)	*
3	Magnification Lens 1.5x	P7-ML15
	Magnification Lens 2.0x	P7-ML20
	Magnification Lens 2.5x	P7-ML25

*Commonly available from most battery retailers.

6 / MAINTENANCE

The helmet and ADF must be checked regularly. Defective equipment should not be used. Parts that are broken, missing, worn, distorted or contaminated, should be replaced immediately.

- a. Inspect lenses frequently. Immediately replace any scratched, cracked, or pitted lenses as they may impair visibility and reduce protection.
- b. Inspect Helmet Shell and Harness Assembly frequently. Replace any damaged or worn components immediately.
- c. Keep the Sensors and the Solar Panel clean at all times. When cleaning the Welding Helmet or Filter Lens do not use solvents or abrasive cleaning agents. Clean with a soft cloth after use.

7 / TROUBLESHOOTING

FAULT	POSSIBLE CAUSES	POSSIBLE REMEDY
The Filter Lens does not activate at all (fails to darken)	Batteries are discharged	Replace Batteries
	Batteries are not fitted correctly	Check batteries (see section 4)
	Battery or terminals are dirty	Inspect & clean battery/terminals
The Filter Lens flickers or intermittently fails to darken	Front Cover Lens is dirty or scratched & is obstructing the sensors	Replace cover lens
	Sensors are dirty	Clean the Sensors with a soft cloth
	Sensitivity too low	Increase sensitivity level
	Momentary disruption to sensing of the arc	Increase delay time adjustment (will help compensate for momentary disruptions)
Filter lens is dark when no arc is present or stays dark after the weld is extinguished	The ambient light level is too bright	Reduce the ambient light level in the area
	Sensitivity too high	Reduce sensitivity level

8 / WARRANTY

See www.weldclass.com.au/warrantyinfo for warranty information, and terms and conditions.

Weldclass®

 **WARNING** 

THIS PRODUCT CONTAINS A BUTTON BATTERY
A lithium button battery can cause severe or fatal injuries in 2 hours or less if it is swallowed or placed inside any part of the body.
Keep batteries out of reach of children.
If you think batteries may have been swallowed or placed inside any part of the body, seek immediate medical attention.

weldclass.com.au